

HOME

Maintenance Manual

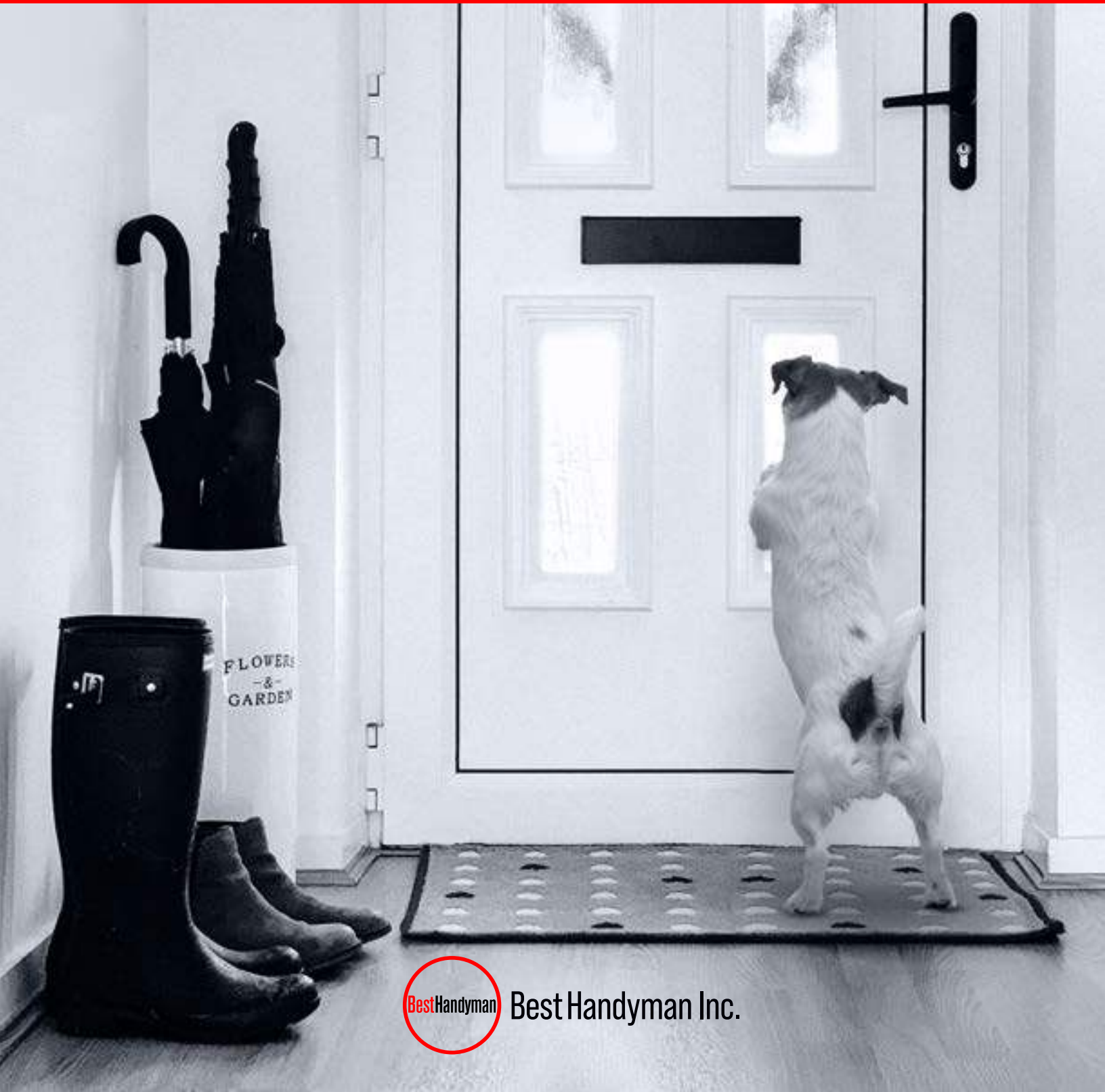

Best Handyman Inc.

3

INTRODUCTION

About this Guide

4

IMPORTANT PHONE NUMBERS

Fast communication matters in an emergency

6

EMERGENCY SWITCH AND VALVE LOCATIONS

Prevention of costly damage to your home starts here

8

HOME EXTERIOR

Get to know the outside of your home and yard top-to- bottom

18

HOME INTERIOR

Your living space needs your love and understanding

24

PLUMBING

One of the most important 24/7 functions in your home

30

ELECTRICAL SYSTEM

The delivery of the energy that enables your home's functions

34

HEATING AND AIR CONDITIONING SYSTEMS

Your comfort all year depends on these systems every day

38

MONTHLY MAINTENANCE/INSPECTION CHECKLIST

The list that keeps you on the right track for avoiding unnecessary costs

20

GLOSSARY

The words and phrases that repair and maintenance people use

A house is made up of a lot of different parts that are all related and depend on the other parts. For example, if you have a leak in your roof, it can not only damage your roof, but this can cause you to have problems with your ceilings, walls, and your electrical system as well. So, it's very important that you fix a problem when you detect it.

This Home Maintenance Guide will provide you with important information about the different parts of your house. Each section will give you several important items to look for as you conduct your routine inspections. As we discuss each part of the house, we will give you preventive maintenance tips that can save you from problems in the future.



Copyright © 2022 Best Handyman INC. All rights reserved. No part of this publication may be reproduced, distributed or transmitted in any form or other electronic or mechanical methods, without the prior written permission of the publisher, except in the case of brief quotations embodied in reviews and certain other non-commercial uses permitted by copyright law.

IMPORTANT PHONE NUMBERS

The first thing you need to do is to make a list of important telephone numbers that you may need to help maintain your home. After you've read this guide, be sure to keep it where household members can find it quickly in case of emergencies. It's a good idea to take a few moments now to add these numbers to your mobile phone contacts, too.

In an emergency call 911

Our Address _____ Phone _____

Emergency Contact _____ Phone _____

FIRE & POLICE EMERGENCY NUMBERS

Fire _____ Police _____

UTILITIES EMERGENCY NUMBERS

Electric Company _____ Gas Company _____

Water Department _____ Sewer Department _____

Street Department _____ Phone Company _____



VALVE AND SWITCH

Now, take a minute to find the shut off valves for your utilities. Then write down where they are located so someone else can find them if necessary. Make note of any special conditions about the location of each one or how it works. Also, read the warranty and instructions for all your appliances. Then place all this information in one location so you can find it when you need it.

ELECTRICAL MAIN SWITCH LOCATION _____

WATER MAIN VALVE LOCATION _____

GAS MAIN VALVE LOCATION _____

WARRANTY AND INSTRUCTIONS LOCATION _____



NOTES

HOME EXTERIOR

The exterior of your house is the outside portion. The house exterior includes five major areas:

1

FOUNDATION

The foundation of your house supports the structure that is above it and keeps the structure from shifting.

2

SIDING

The siding of the house is the outside walls.

3

ROOF

The roof covers the top of the house.

4

WINDOWS & DOORS

Windows and doors are openings in the siding and walls of your house.

5

YARD

The yard is that area surrounding your house generally known as your property.

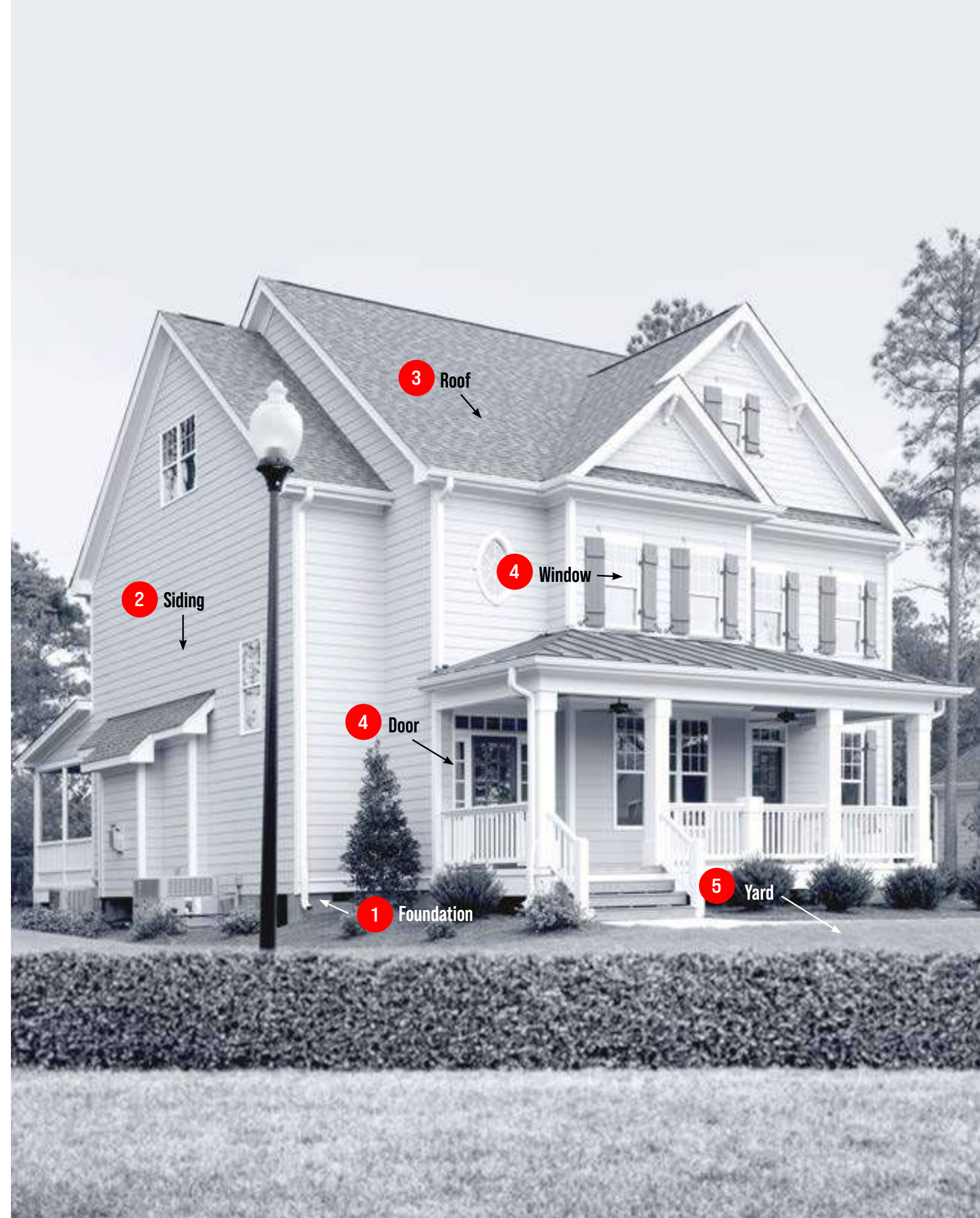

Foundation

The foundation of your house is the part of your house that supports the floor, the walls, the roof and everything inside your home. A well-constructed and properly maintained foundation should last for your lifetime and then some. There are several different types of foundations, but one thing that they all have in common is that they must rest on solid ground. If a foundation is properly built, you should have very few problems if you maintain it. A foundation that is poorly built, either through materials or labor, will only cause you problems later. A foundation can create many different problems inside your house. Some may be very minor and require very little repairs, while others may be major, life-threatening problems that require lots of time and money to fix.

The foundation of every house should be inspected at least two times a year, once in the spring and once in the fall. As your house ages and settles, your foundation can crack, creating new problems. Severe weather conditions such as bad winters, severe summer storms, or long rainy periods can also create foundation problems. The foundation should look like a “foot-print” of your house that is designed to carry the house’s weight. Generally, foundations are built on footers with either a crawl space or concrete slab. If your house has a basement, then your house will have an outside foundation.

Foundation Inspection

The first time you inspect your foundation you should make notes as to your findings and the date the inspection was conducted. You will then be able to check any changes that may occur over the next few years based on your notes.

LANDSCAPING, DRAINAGE AND WATER

To begin your inspection you need to look at the landscaping and drainage around the foundation. You may need to have someone grade the soil so that water will run off away from your house. You should also make sure that any gutters and downspouts will be diverted away from the foundation. Landscaping planted around the foundation will absorb the water and stabilize the soil. However, trees and shrubs with large root systems can damage the foundation.

CRACKS, LEAKS, AND CONDENSATION

Small hairline cracks are common and nothing to worry about. However, cracks that are wider than 1/16 of an inch are important. Wider cracks should be inspected by Best Handyman Inc. to determine the cause of the cracking. Vertical or stepping cracks usually are caused by severe winters where the ground has frozen and expanded, thereby putting pressure on the foundation. Cracking can also be caused by a “settling” of the foundation. Settling cracks will occur when the foundation was not poured on solid ground. When leaks occur in the foundation, they are generally from improper drainage or condensation.

INSECTS

Insects are a potential problem to consider when examining your foundation. Termites, worms and ants can hide in your house and create problems before you ever know they are there. They generally like dark and damp places that are difficult for the naked eye to detect. You should have an annual termite inspection to ensure that you keep your house free of termites and insects.

Foundation Maintenance

Low-lying shrubs and ground cover, like grass or mulch, will allow the soil to drain away from the foundation and will keep the soil around your foundation stable. Plants should not be planted next to walls of your house. Flowerbeds should be planted several feet from the house. This allows for adequate drainage of the soil and limits the moisture and condensation. Small hairline cracking can be prevented by keeping the soil around the foundation as dry as possible. If the foundation was properly installed and if the ground surrounding the foundation drains properly, cracking will be minimal. Another important element is the ventilation of foundations.

If you have a crawl space or basement, this area should be properly ventilated to prevent condensation and the build up of moisture between the ground and the subflooring. Condensation occurs when the cool foundation is met by warmer air. Proper ventilation can eliminate condensation problems. Vents should be left open during the summer and closed shut during the winter. The treatment and prevention of termites is not a do-it-yourself project. It takes a complete understanding and knowledge of how and where the insects live. You should hire a properly trained professional exterminator to get rid of the insects. The best way to keep insects out.

Exterior Walls

The exterior walls and siding of your house should be weather tight to prevent water damage and drafts. Peeling paint, damaged shingles and open seams in siding and trim are not only unsightly, they invite serious problems. Proper maintenance of your exterior walls will help you avoid costly damage of the inner walls. Exterior walls are made up of framing, insulation, sheeting paper, siding and trim.

Each item plays an important part in making your house weatherproof which will keep you dry and warm inside. There are a number of different types of siding: wood, vinyl, aluminum, brick and stone. But the simple truth is that siding and trim do not last unless they are well kept on a regular basis.

Exterior Walls Inspections

No matter what type of siding and trim you may have on your exterior walls you need to inspect the walls at least twice a year. Your primary concern will be detecting areas where water may get through your walls. Inspect the walls from top to bottom looking carefully for defects in the surface. It may be necessary to use a screwdriver on the surface to see if wood is rotting. Pay close attention to the walls on the south and southeast sides of the house. These walls get more exposure to sun and to variations in temperature which make them more apt to deteriorate quickly. Keep your note pad handy so you can record the conditions and any changes in the exterior walls of your house.

Exterior Walls Routine Maintenance

As part of your inspection, you should include routine maintenance through periodic cleaning, caulking, painting or staining and any simple preventive repair jobs on an as-needed basis. With vinyl, aluminum and wood siding you may find it necessary to scrub down the dirty surfaces with a cleaning solution. Any hardware store will have cleaning supplies. Always be sure to follow directions and cover

any shrubs and plants beneath your work area. While you are cleaning, look for mildew on your walls. You should clean the mildew with one part household liquid bleach mixed with three-parts warm water. Scrub the surface and let it soak for 15 minutes. Then use a garden hose and rinse the wall thoroughly. If the mildew remains, scrub the walls with a mixture of water and powdered laundry detergent. Remember to protect your skin and eyes from any cleaning solution.

CAULKING OPENINGS

Caulking and sealing open joints and seams in the exterior walls should be a priority in your routine maintenance program. Openings will allow moisture, water, drafts and insects to creep into your house. Caulking dries out over time, so don't be surprised to find yourself caulking each year. Caulking is a simple process that you can perform using a caulking gun and a putty knife. Make sure you are using the right kind of caulk for what you are sealing. Your hardware store can help you select the correct caulk.



PAINTING AND STAINING

If you keep the paint on your house in good condition, the joints and seams well caulked and the wall surfaces clean, you will greatly reduce the chances of wood decay and moisture getting into your house. Paint will blister and peel over time due to exposure to sun and weather. When this occurs, you are allowing water to get into your house. The correct way to repaint a surface that is blistering and peeling is to scrape off all of the loose paint. Wash the area with a mild detergent, then clean off the surface and let it dry completely. Once the surface has dried, caulk the areas that are needed, reset loose nails, putty over holes, and paint a primer coat on all bare surfaces. Again allow the area to dry. Last, apply two coats of paint being sure that each coat of paint dries completely. By preparing the surface, you will extend the time between painting.

If you have metal siding, you will need to follow the same process except you will use a wire brush to clean the surface of dirt and rust. Be sure to use a metal primer before applying the two coats of paint. Painting or staining combined with caulking will keep the wood around the exterior of your house from decaying. Best Handyman Inc. can advise you on the types of paints to use to protect the surfaces you are painting.

BRICK AND MORTAR REPAIRS

It is not uncommon for the mortar between bricks to crack. Again, cracks will allow moisture and water to seep into your house. Repairing mortar is a simple process that most people can do. As with every other repair process, be sure to clean the surface properly. You can remove the small particles by flushing with a hose or by using a wire brush. Mortar can be purchased at any hardware store. You will want to match the color of your mortar, so you may want to take a sample with you when you go to the store. Then mix the mortar and wet the surface that you will be filling. Then press the mortar into the joints with a jointer tool. After a few minutes, clean the excess mortar and allow the joints to dry.

A WORD OF CAUTION

At the bottom of each wall you will find small openings called weep holes. They are there to allow moisture to escape. Locate the weep holes first, and then be sure to leave them open so they can let trapped moisture escape. As with any preventive maintenance, before making repairs to your exterior walls, find the source of the problem. Covering up a problem will not make the problem go away. The longer a problem exists, the more it is likely to cost you to repair. Be sure to go right to the source before making any repairs.

Roofs and Gutters

The roof and the different parts of the roof, such as the flashing, drains, gutters and downspouts, cannot be ignored year after year. Just because you don't have visible leaks doesn't mean that you don't have problems. Don't expect your roof to be problem-free. Proper maintenance can significantly extend the life of your roof. To provide the best preventive maintenance for your roof, you should inspect your roof at least twice a year, once in the spring and again in the fall. It also makes good sense to scan your roof and

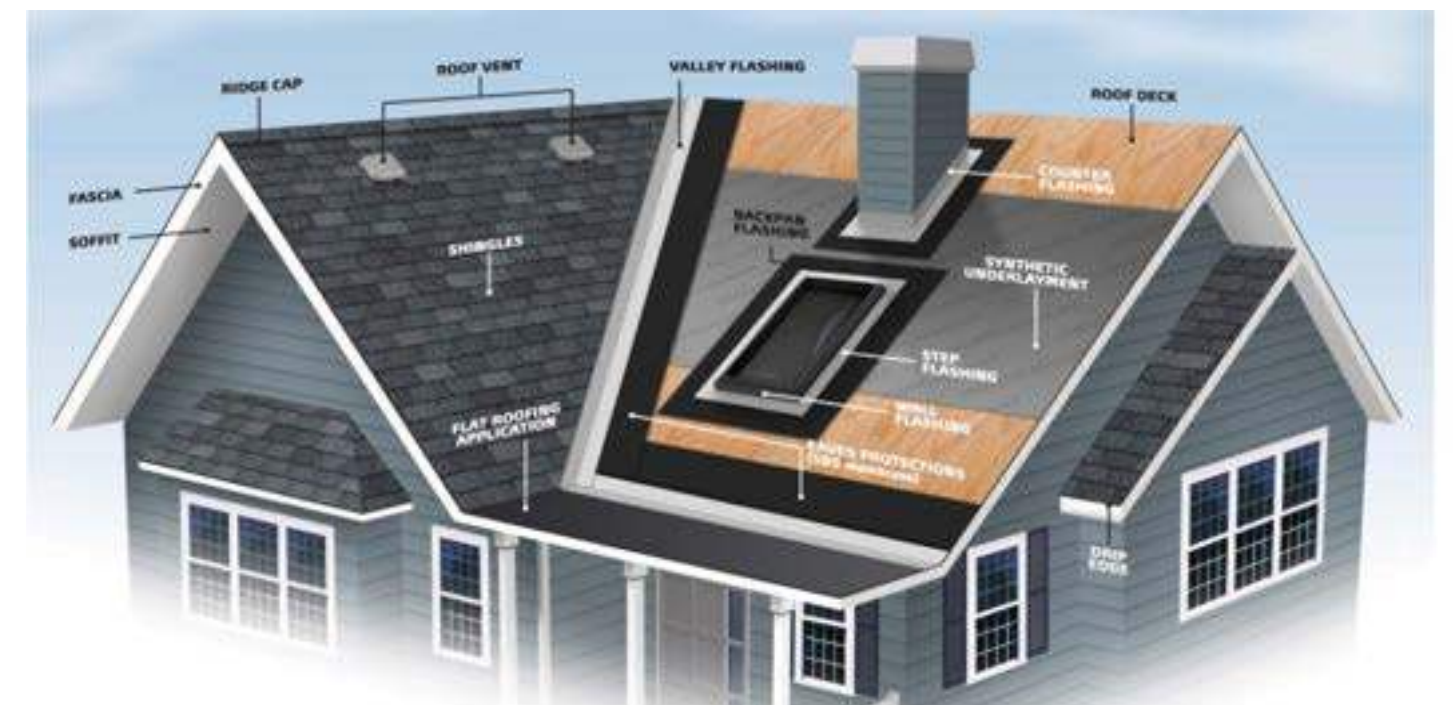

gutters throughout the year. During and after a rainstorm, you can tell if gutters are clear of debris and if you have leaks around vents and fireplaces.

Roof and Gutters Inspection

ROOF COVERING

Shingles are the most common form of roof covering; however, the type of covering will depend on the slope of the roof. You will need to inspect the shingles from the ground, on top of the roof and from the interior portion of the rafters in the attic. If you find that the shingles are curling, cracking, losing their grainy surface, peeling away from the roof and/or changing color; then the roof is showing signs of wear. It may be time to get a new roof. When you perform your inspection in the attic, you will need to look for discoloring of rafters, water marks on the walls and decaying of wood. Water leaks can be from old and decaying shingles. But more often than not, leaks occur around plumbing vent pipes, chimney structures, roof vents and roof valleys.

GUTTERS AND DOWNSPOUTS

One of the most overlooked preventive maintenance measures to your roof is the cleaning of gutters and downspouts. Gutters and downspouts fill up with leaves, pine needles and debris. When the gutters are clogged, this gives water the chance to seep into cracks and back up under the roofing material. Gutters will also spill over on the ground and can cause damp or wet basements and foundations. If you want to limit your cleaning time, you can install plastic or wire screens over the gutters. However, the screens will also need some cleaning.

TREES

One thing many people overlook when performing a routine inspection is the location of trees and branches around your house. Trees and branches close to the house or hanging over the house can be a hazard to your roof. During ice storms or severe wind and rain, it's not uncommon for branches or trees to snap, allowing them to crash on top of your roof. Keep trees and branches clear of the house.

Roof and Gutter Maintenance

When inspecting your roof, safety is a primary concern. If you are going to check the roof yourself, make sure someone is with you in case of an accident. Also, if you are elderly or handicapped, do not get on top of your roof. Hire Best Handyman Inc. to inspect your roof. If you have any of the signs of a roof wearing out (for example: leaks, discoloring, or peeling shingles), it may be time for a new roof. Before you call a friend in to make the repairs, you might want to get an opinion from a Best Handyman Inc. We can give you an idea of what needs to be done to your roof.

Roofs and roof repairs are very specialized, so know what you are doing or get someone that knows what they are doing when roof repairs are needed. When you see the signs of leaks, you need to get a professional to determine the problem. Addressing the problem early will limit the damage and will



Clogged gutters can cause water damage to your basement and roof

cost you less. Remember to keep your gutters and drains cleaned out. This is a simple and inexpensive measure that will save the life of your roof and your foundation. Also, by keeping the limbs and trees trimmed away from your house you lower your risk of damage during storms.

Windows and Doors

Windows and doors are an important part of any house. They provide access, lighting and ventilation into your home. Poorly installed or poorly maintained windows and doors will cause you many problems. If a window or door does not fit snugly, then it will allow hot and cold air to enter your home. Properly installed storm windows and doors will also provide additional security. If the storm window fits loosely or if the glass is broken, the storm window offers no benefit to your house.

Windows and Doors Inspection

Windows are the biggest source of heat loss. Loose-fitting, cracked or missing panes allow your heat to go out the window during the winter. Caulking and weather stripping around the windows are very important. Caulking seals cracks and gaps around windows where frames meet exterior siding. Sealing the cracks and gaps reduces the rate of heat loss in addition to keeping moisture out of your house. Weather stripping is usually installed on windows where the sash and frame meet and on doors where the door and jamb meet along the sides and top. Weather stripping is made of bronze, aluminum, steel and rubber or plastic strips. Weather stripping needs to be replaced periodically, particularly in areas that are used most frequently. You need to inspect all of your windows every spring and every fall. Check the caulking and weather stripping around your window and look for cracked, missing or loosely fitted windows.

Doors not only provide you access into and out of your house, but they also provide you with protection from the outside. First, you need to check your door for operation. Does the door open easily, does the

door close completely and will the door lock securely? Then you need to make sure that the door is not cracked or missing any panes. Use a screwdriver to gently check for rotten wood, loose putty and flaking caulk. When you find these problems, generally it means that there is some type of moisture in your wood. You may be able to make some of these repairs yourself. If you do not know how to make these repairs, get a carpenter to make these improvements. As with your windows, caulking and weather stripping are also very important. Doors that are used most frequently will need to be caulked and weather stripped more often. If your door is still drafty, then you may have a problem with your house settling.

Windows and Doors Maintenance

Inspect your windows and doors twice a year, once in the fall and once in the spring. Repair cracked, loose or broken glass. Scrape and paint any peeling paint on all doors and windows. Replace or repair missing, loose or deteriorated caulking. Repair, tighten or replace any loose or missing storm windows. Patch or replace the screenings on the windows.

Yard

Your yard is the first part of your house anyone sees. So you will want to make sure that the yard is cleaned up to give everyone a good impression of your house. There are a number of other important reasons you will want to keep your yard clean. First and foremost, by keeping the debris and trash picked up around your house, you keep insects, rats and rodents from nesting and making new homes. If your yard is well maintained, you also improve the safety of your house. Yards that are cluttered with appliances, broken-down cars and trash are an eyesore to neighbors. A storage shed in the back of your house, where you can store items, is the safest and cleanest way for you to keep your yard neat.

Yard Maintenance Tips

PLANTS AND SHRUBS

Planting flowers will add color to your yard. Plants and shrubs also help stabilize the soil around the foundation. When planting, be sure to allow some distance between the foundation and your plants. Too much moisture next to the foundation can damage your foundation.

TREES AND LIMBS

Survey your yard for dead limbs and trees. These should be removed. It may require a professional tree surgeon to do this. However, you shouldn't have any problem moving the limbs to the proper place for disposal. Check with your city or county to see who is responsible for disposal of tree and limb debris. You will also need to survey your live trees. Trees that are too close to the house or trees that hang over power lines are dangerous, particularly during windy and freezing weather. By trimming limbs and removing dead limbs you will save yourself from a lot of problems.



How to keep your neighbors happy

KEEPING THE YARD MOWED

You will want to keep the grass cut in your yard. During the summer months yard maintenance is more demanding. During the fall you will want to rake or mulch the leaves.

STORAGE

Keep your yard free from debris. If you have odds and ends in your yard, keep them in a covered shed in the back of your house. Not only will this help eliminate unwanted rats and rodents, **it will keep your neighbors happy.**

HOME INTERIOR

The interior walls, ceilings and floors of your house form a surface that covers the structural frame, plumbing, electrical system, heating and cooling ducts and other building components that would be unsightly or hazardous.

This is why it is important to examine the interior of your house. For example, a leak in your plumbing can damage your walls, foundation and electrical system.



Interior Inspections

The interior walls, ceilings and floors of your house form a surface that covers the structural frame, plumbing, electrical system, heating and cooling ducts and other building components that would be unsightly or hazardous. Since the walls, ceilings and floors cover the areas you are inspecting, you need to use your senses of sight and smell. You also have to train yourself to spot changes over time. Inspection of the interior of your house should be an ongoing process. As you clean your house, look for changes in the

level of the floor, cracks in your walls, damp spots on your walls and floors. When you think you have found an area that may have changed, take the extra time to explore the problem. You want to catch a problem early before more extensive damage is done to your house. The following items are some warning signs that you should examine closely.

SAGGING CEILINGS AND WALLS

When inspecting your ceiling and walls, first make sure your room is well lit. Then look carefully at your ceilings and walls. Sagging ceilings may be a sign of loose wallboard or plaster and should be inspected more closely. Bowed walls may indicate a weakness in the structural framework. Minor localized sagging or softening of walls or ceilings may indicate a water leak above or behind the area. Water travels along the framework of your house and will settle in the lowest point. A leak in one area of the house may be noticed in an area that is far from the actual leak.

CRACKS IN WALLS AND CEILINGS

Cracks come in many sizes, shapes and forms. All cracks need to be looked at to determine the cause. Very fine, straight cracks that are parallel to the walls and ceilings generally are of no great concern. They can be repaired with a flexible caulking and touched up with paint. Look closely with a magnifying glass at joints where two pieces of wallboard come together. Normally these joints are covered with paper tape and layers of joint compound. If you find a crack at a joint, only cosmetic repairs are necessary. You will need to watch the area over time to see if it occurs again and increases in size. Cracks may change size from season to season as your home expands and contracts with the weather. If the cracks grow wider over time, you should call a professional to inspect your foundation. Cracks at angles, jagged cracks and open cracks need to be looked at more closely. If the cracks occur over a short period of time, look for the source. Poor drainage outside your home or standing water underneath it, may be causing the soil to heave and shift the building. An improperly constructed foundation in a freezing climate could be another cause.

CRACKS IN FLOORS

Cracks that appear in concrete slab floors or in rigid floor coverings such as ceramic tile should be closely analyzed. Trace the cracks to the outside wall where the face of the foundation is exposed. Here you can see if the crack runs up the wall or even through the foundation itself. Hairline cracks are common in any concrete structure. However, if the crack is wider than 1/8 inch, it should be further inspected and addressed

SAGGING CEILINGS AND WALLS

When inspecting your ceiling and walls, first make sure your room is well lit. Then look carefully at your ceilings and walls. Sagging ceilings may be a sign of loose wallboard or plaster and should be inspected more closely. Bowed walls may indicate a weakness in the structural framework. Minor localized sagging or softening of walls or ceilings may indicate a water leak above or behind the area. Water travels along the framework of your house and will settle in the lowest point. A leak in one area of the house may be noticed in an area that is far from the actual leak.

CRACKS IN FLOORS

Cracks that appear in concrete slab floors or in rigid floor coverings such as ceramic tile should be closely analyzed. Trace the cracks to the outside wall where the face of the foundation is exposed. Here you can see if the crack runs up the wall or even through the foundation itself. Hairline cracks are common in any concrete structure. However, if the crack is wider than 1/8 inch, it should be further inspected and addressed.

FLOOR SQUEAKS AND BUCKLING

Wood floors are rarely squeak free. Since green, unseasoned wood is used in new construction, squeaks can occur later when the wood dries out. Squeaks are annoying, but rarely a sign of structural problems. Floors will buckle when they are exposed to high humidity or if they are not properly installed. Wood needs adequate expansion areas. When this is not provided, then the floor will buckle to get the necessary space.

INSECT DAMAGE

Inspection for insect damage needs to be an ongoing effort. The best way to address insect damage is to prevent insect damage. A professional inspection service can inspect your home and periodically spray for insects. Once you spot insect damage, the insects are well on their way to spreading throughout your house. You should look closely at exposed wood baseboards, trim, door and window jambs throughout your home. Small tan or dark brown pellets or a sawdust-like material indicates the presence of wood damage. Dry wood termites like dark, damp spaces. Again, the best way to prevent insect damage is to have your house professionally serviced on an annual basis.



SIGHT AND SMELL SENSES

As you inspect your home, pay close attention to what your nose and eyes are telling you. A musty, damp, stale odor should be tracked at once. Check the crawl space or basement for moisture or damp soil. Look and smell inside closets to determine whether they are adequately ventilated. Check for leaky pipes. Shower water that is continually splashed onto the floor can leak through cracks and cause the floor or subflooring to rot. Check the walls behind furniture and pictures that are not frequently moved. Look for mold and mildew. This is a sign of moisture or poor ventilation. If your carpet smells, the padding may be absorbing moisture.

Pull back your carpet to inspect the padding and floor for rust spots or fungal growth. If the carpeting falls apart when you pull at it, you have a serious moisture problem. Use your eyes to survey for water leaks in your ceilings, walls and floors, particularly around baseboards. A water stain typically appears as a dark ring of discoloration around an affected area. As mentioned earlier, water will move along the framework of a house to the lowest point. When a ceiling stain occurs below an attic, check for leaks in the attic plumbing and use a strong flashlight to inspect the roof frame. Be sure and check the caulking around windows and doors. As caulking gets older, it will crack and separate, allowing water to seep through into the interior of your house.

Interior Maintenance Tips

When you see changes in your walls, ceilings and floors, you should take the time to give them some immediate attention. Here are some interior maintenance tips that will help eliminate some major and costly repairs in the future. Use common sense when spotting changes in your house. The most important maintenance tip is to keep a clean house free from trash and debris

CEILINGS

Ceilings that are newly installed generally need very little attention. However, if you see cracks and water stains they need to be looked into immediately. Most cracks are hairline cracks and do not represent a serious problem. These types of cracks can be easily patched and painted. Remember, every crack needs to be investigated to see if it represents a more serious problem.

WALLS

Most wall damage is caused by simple physical abuse. You can prevent a problem by paying special attention to the care of your walls. Walls need to be periodically cleaned by a nonabrasive household cleaning product. You should find out the type of paint used on your walls and make sure that your cleaning solution is suitable for the surface. If you paint your walls, then you should be sure to use the type of paint that is suitable for your walls. You can always use oil based paint over any type of paint. However, you can not paint water based paint over oil based paint. Structural problems with walls are indications of a more serious problem within the interior walls or the foundation of the house. When a problem is discovered, it is important to determine the cause of the problem. This may require a Best Handyman Inc. to look into the problem.



ODORS AND MILDEW

You can do a lot to control mildew and musty doors. Check all ventilating systems in the crawl spaces and attic. Replace vent screens that have become clogged by debris or paint. Closets may become musty due to poor circulation. Louvered doors increase air circulation and will help keep your closets smelling fresh. Place your furniture several inches away from the wall to allow ventilation. If your basement or crawl space has a dirt floor, try sealing the exposed earth with a sheet of plastic. This will act as a vapor barrier and will also keep moisture out of your house.

FLOORS

Floors should be maintained by regular cleaning and vacuuming. Regular cleaning can extend the life of your floor. A trouble-free floor depends on good subflooring and the installation of the subflooring.

STAIRWAYS

Stairways are areas where accidents frequently occur. Make sure that handrails are securely attached to the walls and extend the length of the stairs. Each step should be the same depth and distance apart. When a stairway has steps of different heights, you are asking for trouble. Keep debris cleared off the stairs to prevent tripping.

BATHROOMS AND KITCHENS

Bathrooms and kitchens need extra attention because of the constant presence of moisture. Use a strong flashlight to check the plumbing under the sinks. Check behind refrigerators to make sure that water is not running out of your refrigerator and rotting your floor. A sponginess or discoloration of the floor covering around the toilet could mean a leak in the seal where it connects to the floor. Look for damaged or missing caulking between the tub, sinks, toilets and the walls and floors. Joints between bathroom walls and sinks, bathtubs or showers require caulking. It can not be over emphasized that caulking is a simple and inexpensive method of moisture proofing that can save you hundreds of dollars in later repairs.

The kitchen cooking areas need inspection about once a month. Check your range ventilator hood for grease build-up and keep it clean. This will reduce the risk of fire due to grease build-up. Light bulbs covered with grease should be cleaned or replaced.

SMOKE ALARMS

Each house should have at least one smoke alarm. If you have more than one level to your house, you should have one smoke alarm for each level. You should locate a smoke alarm in each bedroom. Smoke alarms operate on batteries or on electricity. If you use batteries, then you will need to change your batteries twice a year. Smoke alarms are essential to the health and safety of your home.

Who Should Do The Work?

Normal routine inspection and maintenance will eliminate the need for a costly professional in most cases. By addressing a problem or potential problem early on, you will save a lot of time, money and aggravation. The longer a problem goes unattended, the more costly and more involved it will be to solve. Most of the home maintenance tips presented here can be done by yourself as long as you have the tools, time, know-how and ladders. Having a good plan in place for your home is the best investment you can make.



PLUMBING

The interior walls, ceilings and floors of your house form a surface that covers the structural frame, plumbing, electrical system, heating and cooling ducts and other building components that would be unsightly or hazardous.

This is why it is important to examine the interior of your house. For example, a leak in your plumbing can damage your walls, foundation and electrical system.

Foundation Maintenance

If you are on a public water system, then you pay a monthly water bill and the utility company is responsible for providing you with water. Your responsibility begins at the property line. The utility company will bring the water to your property, then you are responsible for the water getting into your house. If you are on a public water system, the water should enter your house at 20 to 80 psi (pounds per square inch). If your water pressure is low, you need to check with the utility company to see if it has adequate sized lines with the right amount of pressure to serve your home. If you live in an older home, the water line leading into the house may be undersized or corroded from age. If this is the case, you may need to replace the line leading into your house. Some homes may use a well to provide water.

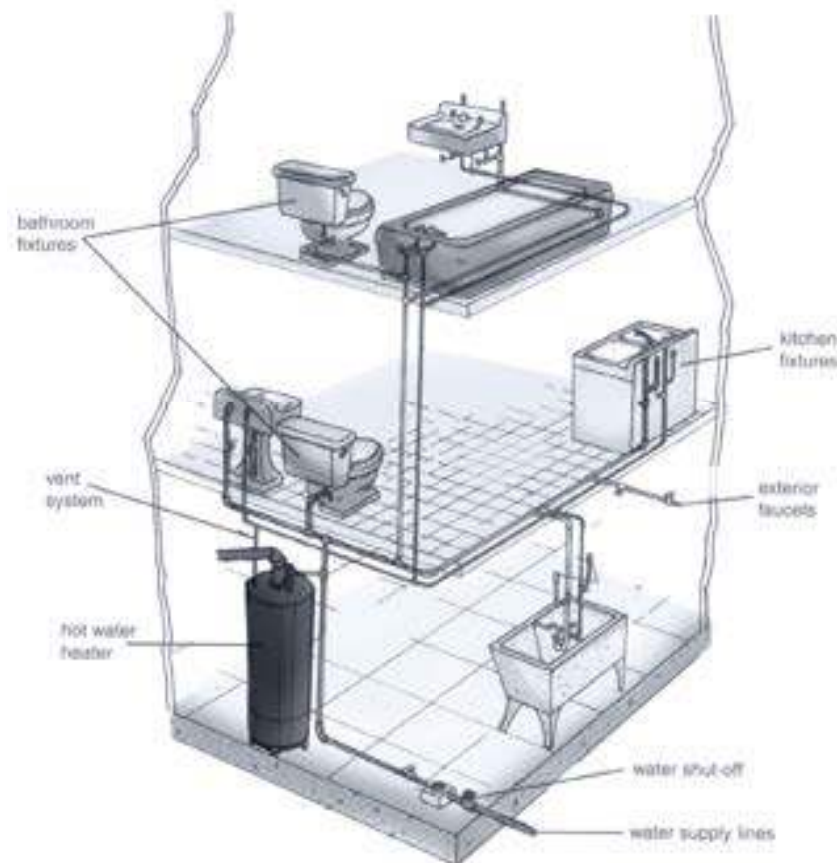

Underground water is pumped into a pressure tank. As your house demands water, the water is pumped into the house and the pressure tank is refilled. If you use a well, then periodically you will need to have your well professionally inspected. If you have problems with your water supply, hire a professional to inspect and maintain your water lines. Take note of your water bill. If your water bill is suddenly higher, you could have a leak in the ground. Also, if your water bill gradually increases, you could have a small leak in the house. Remember, when you water plants in the summer, you pay for the extra water. When you have problems with delivery of water to your house, call your utility company and ask them to inspect the lines. Keep in mind that you are responsible for maintaining the water line on your property.

THE WATER SUPPLY PIPING

Most water supply lines are made up of galvanized iron, copper, brass or plastic pipe. Older homes may use lead pipes or may have used lead joints to connect the pipes. If you live in an older home, you may want to have your water tested for high levels of lead. If your house contains galvanized iron piping, there is a good chance that your lines have some decay on the inside of the water line. That can be one of the reasons for problems with water pressure and water delivery. Galvanized pipes have a life expectancy of about 30 years. If you are experiencing difficulty in water delivery, you will want to have a professional look at your water lines. Plastic polyvinyl chloride (PVC) pipes can last a very long time since rust or decay will not build up. However, your local codes may limit the use of PVC. If PVC is exposed to cold weather, it will need to be insulated to prevent cracking. Again, you will want our team to inspect and install your PVC pipes.

WATER SHUTOFF VALVES

When water pipes break or leak, the damage to your home can be very costly. If you know how to shut off your water supply, you can prevent further damage to your house. There are several fixtures that have their own shutoff valve such as toilets, sinks, water heaters and washer connections. These shutoff valves are generally located behind or beneath the fixture. In any case, you can always shut off the water at the meter and this will shut off all water leading into the house. You should take the time to familiarize yourself with the exact location of the shutoff valves for your house. You need to check to see if a tool is needed to assist you in shutting off the water. Inspect your shutoff valves to make sure they are fully opened. Then record the exact location of your shutoff valves in the spaces provided in the front of this guide.

Drain Waste System

Used water and waste are carried to public sewage lines or to your septic tank system. One of the most frequent problems with your plumbing system is stopped or slow-draining fixtures and appliances. The best way to prevent problems with your drainage system is to limit the debris you put in your drain. Each drain should be sealed off by a trap. The trap prevents gaseous odors from coming back into your house. If you have a sour or sewage smell in your house, you can pour some water down the drain. This will cause the trap to drain the liquid and create a seal between the drain and your sewer system. If the odor continues, then you will want to have a professional look at your drains.

Vent System

Venting is necessary to maintain equal pressure in your plumbing system and to make sure that any sewer gases escape to the outside of your house. All plumbing fixtures must be vented to the outside. Some vents will lead to the roof while other vents will run to the side of the house. A newer house may have one main vent that connects to all the fixtures. It's important to keep the vents clear of debris. Small animals and birds can build nests in vents. A wire covering is always an easy way to prevent this. Vents should be checked twice a year to make sure that they do not become clogged.

Plumbing Inspections

Many elements of your plumbing can be inspected by you, the homeowner. If you do not feel comfortable inspecting your plumbing, ask a friend or neighbor to help or call a licensed plumber. Do not confuse the plumbing pipes with gas lines or warm-water heating systems.

THE WATER SUPPLY PIPES

First, locate your water shutoff valve. This can be located in a basement, crawl space or outside the house. Know where your water meter is and how to shut off the water pipes at the main water line. Next, notice the type of water lines installed in your house. Make sure that the water lines are supported by floor joists or wall studs. Pipes running under the floor joists should be connected to the joists by pipe straps. Depending on the type of pipe, you should have pipe straps every 3 or 5 feet. Obviously, as you inspect your house you will need to look for any type of leaks. Do not confuse sweating pipes with leaks. If you have a wet pipe, wipe the pipe off with a towel. If the pipe is leaking, it will start dripping immediately. If a pipe is wet from condensation, it will take time to get wet again. While looking at your water pipes, make a note of any pipes that have been patched. Patched pipes should be checked periodically for leaks, or replaced with new pipes. If your basement or crawl space is not heated, the pipes should be insulated or wrapped with electrical heating cable to prevent freezing. This is especially important when pipes are located near windows, foundation vents, or walls that are not insulated.

EXTERIOR FAUCETS

If you have exterior faucets, you need to have frost-proof faucets or have a stop-and-waste valve to prevent freezing. Both types of faucets can be bought at your local hardware store. You may need a professional to install the faucet, or someone that knows plumbing. Another alternative is to install a shutoff valve on the water line leading to the outside faucet. During the cold weather months, it's always a good idea to drain your hoses and store them in a dry, warm area. This will keep your hose from cracking and extend the life of your hose.

THE WATER HEATER

You will need to inspect your water heater on a regular basis. To inspect the water heater you should start at the hot and cold water lines attached to the tank. Carefully touch each pipe to distinguish the hot water and cold water lines. Make sure that metal piping has been used for at least the first 12 inches

above the heater. Check for corrosion or leakage at Locate the shutoff valve on the cold water line leading into the tank. Next, check the pressure and temperature relief valves to make sure they match the tank specifications usually found on the side of the water tank. Carefully inspect the outer metal jacket for rust or signs of leakage. A leaking water heater almost always has to be replaced. Use a towel to make sure it is a leak and not condensation that has wet the outside of the tank. Make sure your water heater is located in a drip pan. In case of a leak in the water heater, this can limit the damage done to your house. Your water heater must be vented to the outside of your house. This is particularly important with gas water heater tanks.

DRAINS AND SEWAGE PIPES

Locate the drainage pipes in your house. They can be easily found by listening for running water. Drains and sewage pipes should have a gradual slope to allow the water to run down the pipe and not get backed up. Pipes should be securely fastened to floor or walls every 4 to 5 feet. Carefully check for leaks under water fixtures such as toilets, sinks and washing machines. All leaks should be repaired immediately. Use a strong flashlight to check all the drains under the sinks. Test a sink drain for leaks by running water into the sink and watching as the sink drains. As the water drains from the sink, listen for a gurgling sound.

THE VENT SYSTEM

Inspecting for vents begins outside your house. You should have vents protruding through the roof or along the walls of your house. Vents should be capped to prevent clogging from outside debris and to keep an airtight seal between the inside and the outside. A simple wire screen will keep small animals and birds from nesting in your vent. Continue your inspection of the vents on the inside of the house. When visible, make sure that vents are properly connected so that the air will vent to the outside. Do not allow vents to stop in your basement or crawl spaces. Vents must end outside of your house. This is very important since sewers create vapors than can be deadly. The same is true with a gas furnace or gas hot water heater. Make sure that they vent all the way to the outside.

SEWER SYSTEMS

Your home should be connected to either the public sewer system or to a septic tank in your yard. If you are on public sewer, you are responsible for getting the sewer lines from your house to your property line. At that point the utility agency is responsible for transporting the sewage. If sewer lines become clogged, sewage can back up into your house. When this happens you have a very serious health and safety problem. Again, get a Best Handyman Inc. to correct the problem. If you have a septic tank, you need to know its location. Locate the septic tank and the drain fields. The size of the septic tank and the drain field lines depend on the intended use of the septic tank and the type of soil in which the of sediment Refer to your owners manual for instructions on draining your system. Also, inspect the pressure and temperature relief valves for overflows. Again, refer to your owners manual to see if they are operating at their designated specifications. If you have a gas water heater, a professional should check to make sure that it is vented properly.

DRAINS AND VENTS

Each month you should check the pop-up drains and strainers in your sinks. Check the hot and cold faucets to make sure that they will close completely. If you have a leak at the handle, it's probably a worn

out washer that needs replacing. Remember, if you do any work on a water fixture, you should shut off the water either at the fixture or at the main water shutoff valve. Before winter comes you should make sure that the outside faucets are shut off or protected. Cold weather creates a booming business for plumbers. Make sure any exposed pipes or pipes that are not in a heated room, are properly insulated. In very cold weather, you may want to leave a faucet dripping. This will keep the water in the pipes moving and will keep the water from freezing. Freezing causes pipes to expand. When the water thaws, old decaying pipes will burst. When this happens, you should turn off the water leading into the house and call a licensed plumber. Make a habit of running very hot water down your drain on a regular basis. This will help move along any debris that has gotten clogged or built up in your drain. If you smell gaseous odors in your house, pour water down the drain and then check the venting.

WATER SUPPLY

If you are a public water customer and you have low water pressure or a limited water supply during the day, report the problem to the utility agency. If the utility agency can not correct the problem, you may first need to replace you water line from the water meter to the house. Then replace the water lines in your house. Check with nearby neighbors to see if they are having water pressure or water supply problems. If you are on a well and you have discolored water, limited water supply or particles in your water system, you need to have your well inspected. Wells can dry up over time and during dry weather periods. Also, check to make sure that your well and septic tank are properly spaced. If you have problems with discolored water, or water that smells or water that tastes funny, you should have your water tested. Private labs, utility agencies, and some County Health Departments can provide this service for a fee. Call the lab where you are going to have your water tested and ask them to instruct you about the proper procedure for collecting the sample.

Hiring a Professional

If you are going to get bids from several plumbers, check with them before they make the trip to your house. To protect yourself, you should have a written agreement for the work to be performed. Even though we recommend that you perform routine maintenance tasks, it may be necessary to call a plumber for certain items. It's best to maintain your plumbing system properly rather than waiting to find someone when a disaster happens. Use common sense with your routine maintenance and with necessary repairs that are needed over time.



ELECTRICAL SYSTEMS

Electricity is an essential utility that operates the majority of our appliances, our lighting and, in some cases, our heating and cooling systems. It is a utility that we have learned to depend on, and we find it most aggravating when our electrical service is interrupted.

All electrical work and inspections should be performed by a licensed company only.

Working on your electrical circuitry is dangerous and can be deadly even to someone who understands how electricity works.

Even though we do not recommend that you work on any electrical improvements, there are some things about electricity you should understand. You need to know how and where electricity enters your house. Does your electricity enter the house through an overhead wire or does it enter your house through an underground conduit? The electric company is responsible for providing electricity to the meter. Once the electricity passes through the electric meter, it becomes your responsibility. The electricity is then tied into an electrical service panel. Once inside the electrical service panel, electricity is distributed to the different circuits within your house.

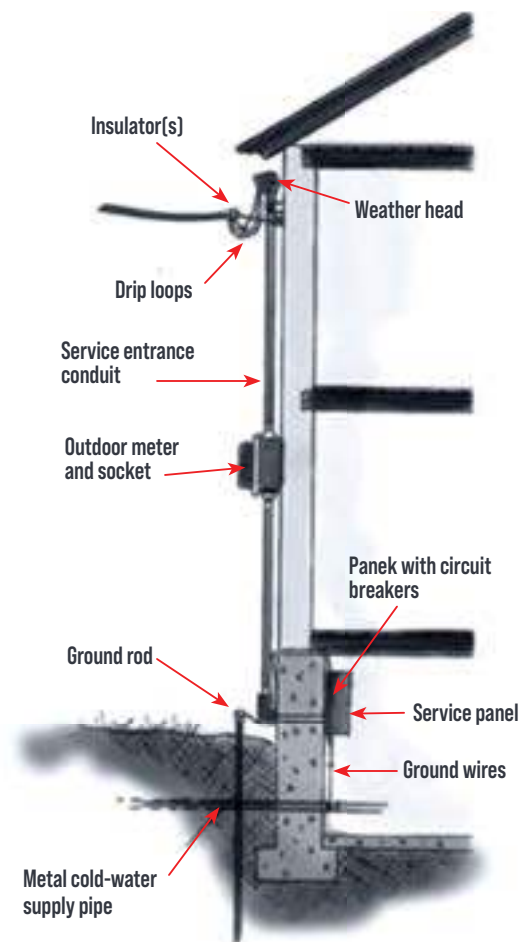

Electrical Inspections

Your inspection of your electrical system will be entirely visual. Do not insert or probe any type of tool into any electrical panel or connection.

SERVICE ENTRANCE

If you receive your electrical service from an overhead wire, you need to make sure that the service line is properly connected into the house. The electrical cable should be high enough that no one can reach it from the ground or from any attached steps. You will also want to make sure that the cable is not in the path of any falling limbs. During ice storms and heavy wind and rains, it is not uncommon for a tree or some branches to fall. An electrical cable will not hold a falling tree. Instead, the cable will snap or be pulled away from the house. When this happens, you are without electricity until the electrical company can restore the line. Most residential service has 240 volt power. If your home is older, you may have 120 volts. You might consider updating your electrical circuits. Again, this is a job for a professional electrician.

ELECTRICAL WIRING

Electrical wiring should be concealed behind the wall. However, sometimes it is necessary to run electrical wiring outside of the wall. When this occurs, all wiring must be run through a conduit to protect the wiring. You should also notice that as wiring becomes old it will crack and expose the metal inside the wire that conducts the electricity. This old, faulty wiring is a fire hazard and should be replaced. Do not attempt to replace any wiring yourself. A Best Handyman Inc. understands the current and circuit requirements. Each year we read about numerous fires that have been started due to faulty wiring that could have been prevented.

ELECTRICAL SERVICE PANEL

It is most important that you know where your electrical service panel is located. Go to the section in this Home Maintenance Guide for important numbers and notes and write down where the electricity enters your house. Within the electrical service panel you will find breakers or fuses that protect the electrical current against short circuits. You will also see a main electrical disconnect switch that will turn off all electricity coming into the house. Once the electricity enters the service panel it is then broken down into circuits that provide electricity to specific appliances or areas of your house. Make sure that each breaker or circuit is labeled as to where it is providing electricity.

When a circuit becomes overloaded with electrical demand, the breaker will disconnect. When this occurs, you should first turn off the appliances and lights in that circuit. Then go to your electrical service panel and find which switch has been disconnected. Reconnect or flip the circuit to see if the electricity is restored to that particular circuit. If you flip the circuit and it disconnects or flips back you have overloaded your circuit. Try not to overload your circuits. Always use common sense when dealing with electricity. You will also want to inspect your electrical service panel to make sure it is grounded. The service panel should be grounded either into the ground or attached to a metal cold-water supply pipe. Homes built since 1978 are required to have both grounding connections. Grounding reduces the chances of shock, fire or damage to appliances and motors and helps protect your house from lightning.

ROOM-BY-ROOM INSPECTIONS

As you conduct your room-by-room inspection, notice the electrical plugs. Since the 1960s, builders have been installing outlets where one slot is larger than the other. You will also notice that manufacturers are making one prong of an electrical plug larger. The GFCI outlet is another outlet designed to protect people from severe electric shock. It monitors the current and disconnects the circuit if it senses an imbalance in the electrical current. GFCI outlets are required in bathrooms, kitchens within 6 feet of a sink and outdoors. You will know if you have a GFCI outlet because there will be a red button labeled test and reset or T and R.

You should test your GFCI at least once a month by pressing the test button and resetting it. You can test every outlet in your house by using a circuit tester or a small lamp. A circuit tester can be purchased at any hardware store. A circuit tester indicates if an outlet has energy and if it is correctly wired. Again, if you have electrical problems, don't attempt to make the correction yourself. Call a Best Handyman Inc. to do your electrical improvements.

As you inspect each room, check the light switches and the light fixtures by turning the switches on and off to see if they operate properly. If you have any light fixtures that have hanging cords from the ceiling, check the wiring very closely. If the wiring and/or insulation around the wiring is cracked, you need to have it replaced. Extension cords can also be a hazard. If you have to use them, your home probably requires additional electrical outlets. Extension cords should never be secured with nails or staples, run through walls, under doors or under carpets. Also, the size of the wire of an extension cord should never be thinner than the cord of the appliance it serves.

Electrical Inspections

Check your monthly electric bill for substantial increases. Remember, you are billed on the amount of electricity used. The best way to reduce your electric bill is to reduce the amount of electricity used. Simple things that will help are turning off the lights when you leave a room and turning off appliances when not in use. Also, remember that heating and cooling with electricity will substantially increase your electric bill. If you still think your electric bill is high, you can contact the electric company and have them check the meter. There are several things that you will need to check from time to time.

Every spring or fall you will need to check the overhead service line that connects to your house. Make sure that trees and limbs are a safe distance away from the line. If you need to prune trees around the overhead service line, contact a Best Handyman Inc. or, in some cases, your electric utility company will trim upon request. Check your electrical service panel to make sure you can locate the panel.

Once a year you should exercise the breakers by flipping them off and on by hand to make sure that they will trip when necessary. Overloaded circuits are often indicated by flickering or dimming lights when appliances are turned on and by frequently blowing fuses or tripping circuit breakers. If you frequently trip the circuit breakers, this may indicate that you do not have adequate service for your electrical demand, or that you are overloading that one particular circuit. Try moving appliances and lights to other outlets.

HEATING & AIR CONDITIONING

Heating a house is essential during cold weather. If your house is not heated, then all the other systems in your house are at risk. Pipes will freeze, electric circuits will become overloaded, and you are putting yourself at risk.

If you recently had your house remodeled or a new house was constructed, your heating system should be adequate for the size of your house. As with your electrical system, the inspection on your heating system should be conducted by a professionally licensed company. However, you can use your sight and smell for inspections and to detect problems.

Heating Inspection

There are many different types of heating systems but each system is based on the type of energy you use. Determine what type of heating system you have and what type of energy you are using to heat your house. It could be gas-fired, coal-fired, electric heat, wood-burning, steam heat or a combination of these. Determine if you have a central heating system or if your house is heated by individual units.

Once you have determined the type of heating system you have, you should have a professionally licensed company inspect your unit. If you have a central heating system, then you will have a central thermostat that gives you a temperature reading. As the temperature changes within your house, the heat will turn on and off to keep the temperature of the air constant. The colder the weather, the more demands that will be placed on your heating system. The less cold air allowed in your house, the less heat you need and the lower your heating bill will be. For that reason, it's important that your house is insulated.

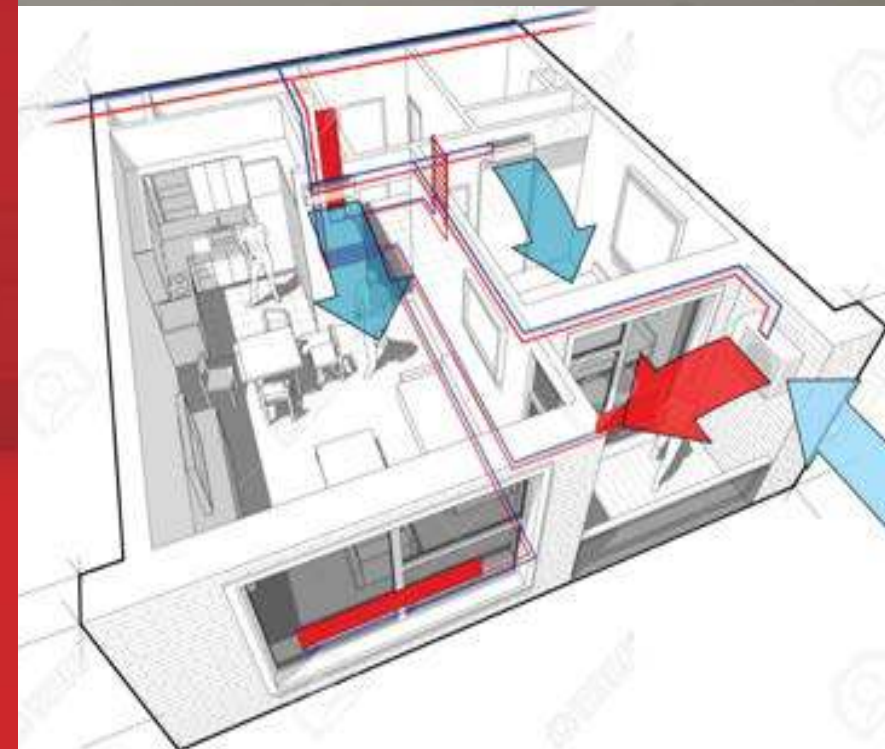

Heating Inspection

There are many different types of heating systems but each system is based on the type of energy you use. Determine what type of heating system you have and what type of energy you are using to heat your house. It could be gas-fired, coal-fired, electric heat, wood-burning, steam heat or a combination of these. Determine if you have a central heating system or if your house is heated by individual units. Once you have determined the type of heating system you have, you should have a professionally licensed company inspect your unit. If you have a central heating system, then you will have a central thermostat that gives you a temperature reading. As the temperature changes within your house, the heat will turn on and off to keep the temperature of the air constant. The colder the weather, the more demands that will be placed on your heating system. The less cold air allowed in your house, the less heat you need and the lower your heating bill will be. For that reason, it's important that your house is insulated.

Heating Inspection

Heating and systems are expensive to replace. For that reason, we recommend that you have your licensed heating system professional inspect your system once a year. If you will do this in September or October, you should have a problem-free winter. If you have electrical heat, one of the easiest maintenance tasks that each homeowner can do is change or clean the filter every month. By changing the filters you allow your heating system to operate more efficiently. This will save you money. You can conserve heat by insulating your house with storm windows and storm doors, attic insulation and even do-it-yourself plastic seals. Insulating windows and doors will reduce the amount of heat loss from your house. This will also reduce your energy bill and save you money. If you smell gas or oil, you should immediately turn off your heating system and call the gas or oil company.

Don't try to make the repairs yourself. Today's gas fired heating systems have a safety measure installed so that if your pilot light goes out, then the gas automatically shuts off. You will know if the system isn't working because your house will get colder and colder. If you have baseboard heat or a wall mounted heater, you should vacuum the heater once a month. Be sure that the unit is turned off before you start your cleaning. You should also keep objects from coming into direct contact with the heater. The newer units have protective screens that keep anything from touching the coils. Every heating system is different. For that reason, use only a licensed professional who is familiar with your system for routine inspections, repairs, and maintenance.

Air Conditioning Systems

There are two primary types of air-conditioning systems used in homes today: (1) central air-conditioning systems powered by electricity or gas, and (2) electric window units. There are several different variations of central air-conditioning units and some are combined with the heating system. As with heating systems, a licensed heating and air-conditioning professional should perform the routine inspections and maintenance of the system.

Air Conditioning Maintenance

Again, you should only attempt to conduct a visual inspection. If you have problems call a Best Handyman Inc. Your air-conditioner should be inspected annually, usually during May or June when the outside temperature is above 60 degrees. As with your heating system, you need to know what kind

of air-conditioning unit you have and what type of energy to use to operate the system. With a central air-conditioning system, you can determine if it is functioning properly by a simple test. Hold a 12-inch piece of yarn over the air-conditioning vent. The breeze should be strong enough to make the yarn flutter. Depending on the temperature, you may want to adjust the openings of the air vents. For example, the side of the house that is getting afternoon sun will require more cooling due to the exterior heat. A window unit air conditioner should be inspected once a year when the outside temperature is above 65 degrees. Each spring you should check the unit to make sure that it is securely attached in the windows. No vines or other obstructions should be wrapped around the outside case. Inspect the caulking around the window unit, both the inside and the outside of the house. Make sure that any old decaying or cracking caulking is replaced. A window unit air conditioner uses electricity to cool. Read the directions and make sure that you have adequate voltage to operate your system. Most window units will have at least a three-prong plug. Never twist or cut off the round prong to force the plug to fit your electrical receptacle or circuit. Best Handyman Inc. can determine if you have adequate voltage to operate a window unit. An improper electrical connection may damage the unit or cause an electrical fire.



Monthly Home Maintenance & Routine Inspection Checklist

If this seems like a lot of things to keep up with every year, you're right! This is why Best Handyman Inc. offers annual maintenance plans designed to take the worry out of owning a home.

1YR 2YR 3YR JANUARY

- F F Clean and replace air filters.
- F F Don't overload any single electric circuit.
- F F Inspect heating system for safety.
- F F Check the attic for condensation during colder days.

1YR 2YR 3YR FEBRUARY

- F F Clean and replace air filters.
- F F Don't overload any single electric circuit.
- F F Vacuum coils on refrigerator.
- F F Make sure every electrical plug has a protective cover.
- F F Make sure that all electrical wires are under the floor.
- F F Make sure all electrical fuse boxes, junction boxes and switches are covered.

1YR 2YR 3YR MARCH

- F F Clean and replace air filters.
- F F Don't overload any single electric circuit.
- F F Check the foundation of the house.
- F F Clean the gutters, gutter strainers and downspouts.
- F F Clean up the yard from winter storms. Remove dead and fallen trees and limbs.
- F F Check gas connections.
- F F Drain your hot water heater

1YR 2YR 3YR APRIL

- F F Clean and replace air filters.
- F F Don't overload any single electric circuit.
- F F Check the exterior walls of your house.
- F F Replace or repair the door and window screens.
- F F Inspect the roof for loose or damaged roofing materials.
- F F Check for any signs of water damage or dampness.
- F F Change smoke alarm batteries.

1YR 2YR 3YR MAY

- F F Clean and replace air filters.
- F F Don't overload any single electric circuit.
- F F Check for termites and other pests.
- F F Check the painted surfaces of the house.
- F F Check the roof for loose shingles.
- F F Check the roof for loose shingles.

1YR 2YR 3YR JUNE

- F F Clean and replace air filters.
- F F Don't overload any single electric circuit.
- F F Check the basement for dampness.
- F F Check the locks and latches on all doors and windows.

WE START WITH A PLAN THAT SETS YOU FREE

Best Handyman Boston meets in person to discuss an annual plan for your home. From there, we bring decades of experience to come up with a detailed monthly maintenance plan for you. Then, our technology makes everything easy for you.

1YR 2YR 3YR JULY

- F F Clean and replace air filters.
- F F Don't overload any single electric circuit.
- F F Inspect and make necessary repairs to flooring throughout the entire house.
- F F Check the painted surfaces of the house.
- F F Check the roof for loose shingles.
- F F Check the roof for loose shingles.

1YR 2YR 3YR AUGUST

- F F Clean and replace air filters.
- F F Don't overload any single electric circuit.
- F F Wash and clean interior walls.
- F F Make necessary repairs to any damaged walls.
- F F Drain your water heater

1YR 2YR 3YR SEPTEMBER

- F F Clean and replace air filters.
- F F Don't overload any single electric circuit.
- F F Check insulation in your house. Check insulation in the attic.
- F F Check the exterior walls/siding of your house.
- F F Check the foundation.

1YR 2YR 3YR OCTOBER

- F F Clean and replace air filters.
- F F Don't overload any single electric circuit.
- F F Check the caulking around windows and doors.
- F F Secure weather stripping around windows and door.
- F F Replace or repair any damaged glass on windows or doors.
- F F Clean gutters, gutter strainers and downspouts.
- F F Clean chimney and make necessary repairs.
- F F Change smoke alarm batteries.

1YR 2YR 3YR NOVEMBER

- F F Clean and replace air filters.
- F F Don't overload any single electric circuit.
- F F Clean dead plants, leaves and garbage from around the house and yard.
- F F Check gas connections to make sure there are no leaks.
- F F Check your roof for loose shingles.

- F F Clean out the downspouts and gutters.
- F F Insulate all exposed water pipes to prevent freezing

1YR 2YR 3YR DECEMBER

- F F Clean and replace air filters.
- F F Don't overload any single electric circuit.
- F F Check all faucets, hoses and valves for leaks.
- F F Check for any exposed electrical wires.

GLOSSARY

Caulking is the sealing of open joints, gaps and seams in exterior wall covering. Caulking keeps the exterior air and water from entering the house. Most doors and windows are caulked around the rim of the opening.

Conduit: Conduit generally refers to a tube or duct that covers electrical wiring within the walls or along exterior surfaces.

Crawl Space: The space between the ground and subflooring of the first floor. Generally, this area is bare soil and is an unheated part of the house.

Downspouts: Downspouts are that part of the gutter that carry water off the roof and away from the house and foundation.

Electrical Service Panel: The electrical service panel is a box that houses the point where the electrical service enters the house and is distributed to the electrical system. It is usually located near the electric meter box. The electric meter box is that point where the electric company delivers the electricity to the house.

Flashing: Flashing is sheet metal or some other durable material that is used to seal joints in roofs. Generally used when one material meets another, for example when shingles meet bricks.

Footer: A footer is the base of a foundation. A footer is placed on solid soil and the foundation is built up from the footer.

Grade: The grade of the ground or surface is the angle of the ground.

Grounded: An electrical wire is grounded by running a rod into the earth and by attaching a wire to a metal cold water supply pipe. Grounding reduces the chances of shock, fire or damage to appliances and motors and helps protect the house from lightning. Grounding permits stationary appliances such as washing machines, clothes dryers, refrigerators, ranges and microwave ovens to be used safely.

Gutters: A gutter is installed along the edge of the roof to catch the rain so that it will carry it to the downspout and away from the house.

Jamb: The jamb is the vertical or side piece of the door or window.

Joist: A joist or floor joist is the parallel beam set from wall to wall to support a floor.

Roof valley: The roof valley is where two sections of a roof come together to form a valley. A valley is generally a metal material that is placed over the shingles to channel the water to the gutters and downspouts.

Roof Vents: Roof vents are vents that are installed to allow moisture to escape from inside the house.

Sash: The sash is the frame that holds the glass pane of a window or door.

Settling: Settling occurs in a house over time when the ground under the house shifts. A house can settle because of poor foundation, use of heavy equipment, blasting nearby, earthquakes and/or underground water sources.

Storm Windows and Storm Doors: A storm window or storm door is an additional glass covering installed over a door or window. A storm window or door reduces the heat loss from a house.

Subflooring: The subflooring is the surface that is under the finished floor. The most common examples of subflooring are wood, concrete, and mortar beds. material that is placed over the shingles to channel the water to the gutters and downspouts.

Roof Vents: Roof vents are vents that are installed to allow moisture to escape from inside the house.

Sash: The sash is the frame that holds the glass pane of a window or door.

Settling: Settling occurs in a house over time when the ground under the house shifts. A house can settle because of poor foundation, use of heavy equipment, blasting nearby, earthquakes and/or underground water sources.

Best Handyman's founder, Ryaan Tuttle shares an intimate look into the repair and maintenance of homes. From a young age, Ryaan found his way through repairing and renovating the older homes of Boston, while becoming a master craftsman and founder of Best Handyman Inc.

Tuttle knows these homes inside, outside, and under their skins. He has tackled every aspect of home maintenance including his client's distasteful midnight emergencies. He knows most of these situations could have been avoided with preventative maintenance, and a keen eye for recognizing trouble ahead. Now, after 20 years of experience, Ryaan documents his deep working knowledge of home maintenance with homeowners and craftsmen alike.

He discusses the things that an ambitious DIY'er can fix and those that may require a professional's knowhow. Ryaan's Guide covers problems that are obvious to see and quite simple to fix. And signs of hidden issues that, when left unattended, will surface as costly disruptions to comfort and wellbeing.

The Home Maintenance Guide is a must-read for every homeowner who wants to keep the most valued asset in their portfolio up and running.

About Best Handyman Inc.

Best Handyman Inc offers homeowners a unique approach to maintaining their homes with confidence: **The BestHandyman Plan.** Under the watchful eye of multi-disciplined experienced professionals, your home is kept on track with periodic inspections and necessary maintenance fixes, top to bottom.



BestHandyman INC

besthandymanboston.com (857) 201-6083